



## PEDESTAL - INTERACTIVE VOICE COMMUNICATION UNIT

The **CB 1-s** is the original Code Blue Pedestal unit and sets the industry standard for rugged construction, full feature availability and high visibility. The **CB 1-s** is easily recognized throughout a full 360-degree area. The user friendly lighted faceplate and the integral area light ensures rapid location in an open environment. The high powered strobe is easily identifiable by security when activated. The exclusive CB3100 speakerphone is designed for maximum reliability and leads the market in system programming flexibility. The **CB 1-s** is an excellent choice for walkways, parks, college and commercial campus areas, open landscape areas and anywhere a freestanding pedestal unit is required.

### STANDARD FEATURES:

- CB3100 Speakerphone
- 3 auxiliary inputs
- 2 auxiliary outputs
- Voice identifier
- Phone line surge suppressor
- Analog telephone connection
- 70w HPS area light with Code Blue Beacon
- High powered strobe
- Lighted stainless steel faceplate
- 120v AC power
- Ultra weather resistant finish
- Vandal resistant hardware
- UV resistant lenses
- 12.75" diameter/ 9' height
- ¼" thick steel construction
- Internal foundation anchor kit
- Passive vent
- ADA compliant

### OPTIONAL FEATURES:

- |  |  |
|--|--|
| <input type="checkbox"/> Two button speakerphone             | <input type="checkbox"/> Overhead camera mount       |
| <input type="checkbox"/> Two button speakerphone with keypad | <input type="checkbox"/> Photocell for area light    |
| <input type="checkbox"/> 2.4 Ghz RF communication            | <input type="checkbox"/> Powered vent                |
| <input type="checkbox"/> Cellular communication              | <input type="checkbox"/> Step-down power transformer |
| <input type="checkbox"/> Night Charge™                       | <input type="checkbox"/> Custom colors               |
| <input type="checkbox"/> 70 watt metal halide area light     | <input type="checkbox"/> Custom graphics             |

**STANDARD FINISH COLORS**

Safety Blue	Gloss Black
Safety Red	Medium Bronze
Safety Yellow	Dark Bronze
Midnight Blue	Cardinal Red
Gloss White	British Racing Green

**GRAPHICS TEXT (WORDING)**

Emergency	Courtesy
Assistaence	Security

**GRAPHICS COLOR**

Reflective White	Reflective Black
Reflective Blue	Reflective Red

Custom colors and graphics from RAL number or sample are available as a special order.

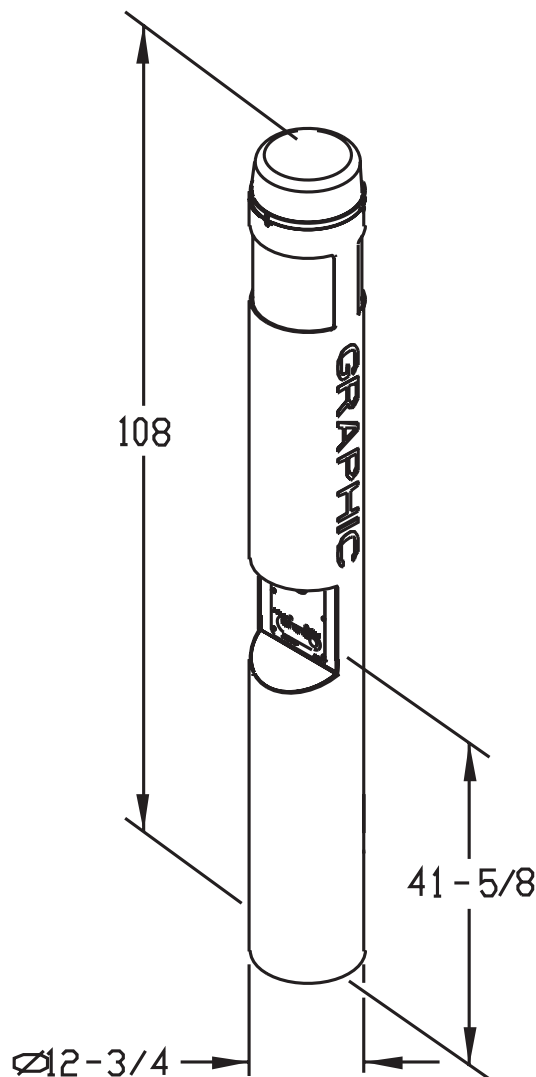
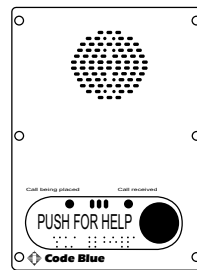
**FACEPLATE OPTIONS**
**FP 1**

Standard Faceplate Assembly with Single red *Push For Help* button

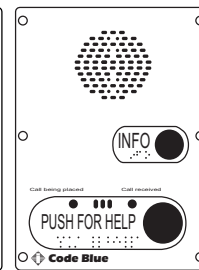
**FP 2**

Optional Faceplate Assembly with additional black *Info* button

**FP 2-K**

Optional Faceplate Assembly with additional *Call* button and keypad

**CELLULAR OPTION**

Provides wireless communications to eliminate trenching for phone lines. System requires a reliable cellular service to be provided by customer.

**NIGHTCHARGE™ OPTION**

Provides continuous power to the Code Blue unit from a non-continuous power source. Typically used with an outdoor lighting network when power is only on during a portion of the day or night.

**CODE BLUE UNIT SPECIFICATIONS**

Overall Height	9'
Outside Diameter	12 3/4"
Housing Material	1/4 inch steel
Overall Weight	375 pounds
Access Opening	8 1/2 x 12"
Standard Power Requirements	120v AC

Mounting hardware and template for each CB 1-s is shipped in advance of unit for foundation work.

## **PRODUCT SPECIFICATION**

### **1.0 GENERAL DESCRIPTION**

1.1 The unit (Code Blue CB 1-s) shall be an easily identifiable, vandal resistant communications device that is Americans with Disabilities Act (ADA) compliant, multi-functional, freestanding, and constructed of heavy steel. The unit shall be aesthetically pleasing and virtually impervious to damage, and shall include a high quality, vandal resistant, hands-free communications device, a powerful strobe light, and a vivid blue beacon that serves to identify the unit from a great distance.

1.2 The communication system (Code Blue CB3100) shall be designed so that a single touch on the communications device button shall immediately and automatically dial a preprogrammed number. This shall simultaneously activate the blue strobe light and an optional peripheral device such as a remote preset for closed circuit television (CCTV). Immediately after establishing the phone connection with the receiving party, the communications device shall be capable of sending a signal identifying the specific unit being activated. The strobe shall continue to flash, drawing attention to this location until the receiving party terminates the call.

### **2.0 CONSTRUCTION**

2.1 The unit shall be a concentric steel cylinder (bollard) with a 12.75 inch diameter, a .25 inch wall thickness, and a height of 9 feet.

2.2 Tamper resistant fasteners manufactured by the McGard Company shall be used. It shall not be possible to enter the unit or remove any component without a special computer designed bit-wrench designed for this purpose. These bit-wrenches are supplied only by the manufacturer of the unit. All other types of fasteners shall not be acceptable due to the abundance of non-proprietary tools available for their removal.

2.3 The unit shall have an internal anchor baseplate that is fully welded to the bollard two inches above its base. The base plate shall be fabricated with a minimum of .50 inch thick A-36 grade steel plate, and shall have a 5 inch diameter center hole for electrical conduit access, as well as four oblong holes on an 8 inch circular bolt pattern for the anchor bolts. External mounting is not acceptable.

2.4 The unit shall have an access opening for anchor mounting and electrical wiring that is near the base of the bollard.

2.5 The opening shall have a cover plate flush with the unit, whose wall thickness and radius shall be the same as the bollard. The cover plate shall fit precisely into the opening, have a weather resistant gasket to prevent water from entering the unit, and shall be held in place by two 1/4-20 by 1 inch countersunk, tamper resistant, proprietary fasteners as supplied by the manufacturer.

2.6 There shall be two lens openings each 10 inches high and 17 inches wide with 153 degrees of arc. The openings shall be cut into the face of the unit 180 degrees apart, with the bottom of the openings to be approximately 14 inches from the top of the unit. The corners of the cuts shall be uniformly rounded, and the edges of the cuts shall be straight and free of burrs and other visual imperfections. The four edges of each opening shall form a square when viewed in elevation from the front or rear of the unit.

2.7 A heavy cylindrical lens made of clear, Lexan XL type polycarbonate shall be inserted into the bollard and mechanically and chemically fastened to the bollard interior. The lens shall be fully sealed with silicon around its entire edge to render the installed lens water, insect, and vandal resistant. The lens shall be treated so that it will be virtually impervious to damage from ultra-violet radiation, aging, cracking, yellowing or breaking.

2.8 A dome top assembly shall enclose the top of the bollard, and shall consist of a cover plate, a gasket, a blue strobe light, and a Lexan type polycarbonate dome cover with a passive vent.

2.8.1 The cover plate shall be of high quality, high-density cast iron that that shall be free of defects. It shall have a diameter that equals the diameter of the bollard, and shall have three tabs each with 10-24 X 1 inch stainless steel thumbscrews to facilitate mounting the finished assembly to the bollard.

2.8.2 A cylindrical, transparent dome that is six inches tall with a 12.50-inch outer diameter shall cover the top of the cover plate. The dome shall be made of clear Lexan XL type polycarbonate, and shall be sloped so that water does not pool on top of the unit.

2.8.3 The dome shall be placed over the blue strobe light and shall fit over the concentric ring in the cover plate. It shall be attached to the cover plate by means of three 10-24 X 1 inch tamper resistant proprietary fasteners attached through the dome and into the three offset tabs in the cover plate. The space between the dome and cover plate ring shall have a bristle style gasket to allow passive venting while minimizing entrance of insect and moisture.

2.8.4 A gasket shall be placed between the dome top assembly and the bollard, and shall provide a weather resistant seal when the assembly is properly installed on top of the bollard.

2.9 A second opening shall be cut into the face of the unit at a point beginning 38.5 inches above the bottom of the bollard. The opening shall be 14.5 inches high at the forward edge, and 12.25 inches high at the rear edge. The lower edge of the opening shall be sloped from the rear to the front at an angle 35 degrees from the horizontal. The upper horizontal edge of the opening shall constitute an arc of 160 degrees in the face of the unit, and the sides of the opening shall be parallel and the same length.

2.9.1 The opening shall be totally enclosed by a 7 gauge steel plate that shall have an opening to allow for a communications device. The plate shall be seal welded to the bollard so that the faceplate and the bollard appear to be one unit.

### **3.0 MOUNTING**

The freestanding unit shall be mounted onto four bolts that are set in concrete. Standard 3/4 x 24 inch galvanized anchor bolts with galvanized nuts and washers shall be used as supplied. Unit shall mount one-half inch above the concrete to allow air movement.

### **4.0 ELECTRICAL**

4.1 All electrical components shall have quick-disconnect terminals for easy service or removal. All wiring shall be concealed within the bollard and shall not be visible from the outside of the unit.

4.2 The unit shall require 120 VAC and draw a maximum of 3 amperes under normal operation. The entire unit shall be surge protected.

4.3 The speakerphone shall require 20 mA loop current at the unit. A 22 to 26 AWG shielded twisted pair cable shall be used. Longer cable runs shall require the heavier gauge cable.

### **5.0 LIGHTS**

5.1 Strobe light – A strobe light shall be located at the top of the unit. The strobe light shall generate approximately 1,000,000 candlepower and have a flash rate of no less than 60 flashes per minute. A deep blue polycarbonate prismatic refractor that distributes the light in a horizontal pattern, making the flash bright and visible even at great distances shall cover the strobe.

5.1.1 The strobe light shall be automatically activated when the “PUSH FOR HELP” button on the communications device is touched, and shall continue to flash until the answering party deactivates the unit. The strobe cannot be turned off at the unit itself.

5.2 Area light/beacon – A high intensity discharge (HID) 70-watt, high-pressure sodium area light shall be located under a reflective disk that is situated within the bollard near the top of the unit. The area light shall be centered between the lenses, and shall be partially surrounded by a heavy-gauge, deep blue, translucent, prismatic refractor made of Lexan type polycarbonate.

5.2.1 Reflectors shall direct the light of the lamp outward and downward from the unit. This shall create a pool of light around the unit, making persons standing near the unit visible to passersby and/or to a responding officer. The area light shall always be illuminated.

5.3 Faceplate light – A long life, LED light fixture shall be concealed within the unit above and directly forward of the communications device. This fixture will direct light onto the communications device faceplate, and shall be vandal resistant.

## **6.0 COMMUNICATIONS**

6.1 The unit shall have a high quality, vandal resistant and ADA compliant speakerphone communications device.

6.2 Standard Speakerphone: (Code Blue CB3100-s)

The speakerphone shall be Code Blue CB3100-s and have one 1.5 inch piezoelectric button labeled “PUSH FOR HELP,” one 3/8 inch diameter red light emitting diode (LED) labeled “Call Placed,” and one 3/8 inch diameter green LED labeled “Call Received.” The speakerphone shall have an internally mounted electronics enclosure, auxiliary power, and shall be capable of playing up to two digitally stored voice messages upon activation. The electronics enclosure shall be capable of using interchangeable faceplates: a single-button faceplate, a two-button faceplate, or a two-button faceplate with keypad. The speakerphone shall be programmable from a remote location and have a three number dialing capability per button. Battery backup shall be rated for 16 hours of active talk time and 32 hours of standby. Line powered phone devices, DIP switch programming, and push-to-talk devices are not acceptable.

6.3 The CB3100 speakerphone shall have the following standard features:

- Three number dialing capability up to 16 digits per button.
- Remotely programmable.
- Remote electronics mounting (extendable up to 5’ with optional 3’ ribbon extension).
- Three reporting inputs (aux one input has optional activation).

- Two output relays (optional aux 2 salvable to aux 1).
- Remote control speaker volume adjustment.
- Silent monitoring mode, password protected.
- Remote control two step microphone sensitivity adjustment
- Programmable passwords.
- Programmable conversation time.
- Allows the black button on a keypad phone to act simply as a hook switch or as a speed dial button before allowing keypad use (for auto dialing into automated systems).
- Detects inaudible hang-up commands from the phone system to allow the CB3100 to detect more accurately when the operator has disconnected from the call.
- Allows for the lockout of “during call commands”.
- Internal watchdog timer to detect and restart the micro controller after a lock up.
- Supports the RPD diagnostic routine that tests the integrity of the microphone and speaker when used with the FP series faceplates.
- RS485 data jack to allow a RS485 device to activate the phone.
- Programming option to set the number of times voice message(s) are played
- Capable of using interchangeable faceplates-single button, dual button and dual button with keypad.
- Re-playable message(s) on demand.
- Output sound level >80 dB at 1 meter for normal conversation.
- Waterproof 3.5-inch speaker.
- Waterproof microphone.
- Operating temperatures of -40°F to +150°F (-40° to +65°C).

- Conformal coated speakerphone electronics to withstand harsh environments.
- Capable of playing messages simultaneously at the unit and to the call center.
- EEPROM Memory ensures that programming is retained during power loss.
- Capable of notification when AC power has been off for 15 minutes.
- Auxiliary power supply, battery back up-16 hours active talk time, 32 hours standby time.
- Highly flexible two stored voice identifiers- includes four modes of operation.
- Easily integrate with CCTV, alarm systems and other security equipment.
- Compatible with 4+1 Express and 4+2 Express Formats.
- Optional AMPS cellular transceiver.
- Optional 2.4 GHz transceiver.
- Complies with FCC Part 15 and TIA/EIA/IS-968.

## **7.0 FINISH**

7.1 The unit shall be finished with a coating process known to be highly graffiti resistant and UV resistant.

7.2 Substrate preparation shall be as required to comply with applicable ASTM impact and adhesion standards.

- D2794 Direct and Reverse Impact
- D523 Gloss @ 60 degrees
- D3359B Cross Hatch Adhesion
- B117 Salt Spray Resistance

7.3 The polyurethane finish shall be a multicoat system available in 10 standard colors and custom colors as specified by the user and approved by the manufacturer.

7.4 The primer coat and finish coat shall each have a minimum coverage thickness of 2.0 mils.

7.5 Other types of protective finishes are not acceptable.

## **8.0 GRAPHICS**

8.1 The graphics shall be a durable engineering grade reflective vinyl for high visibility and legibility.

8.2 The standard graphics text shall be “Emergency,” “Assistance,” “Security,” or “Courtesy” and shall be available in 30 inch lengths. Standard colors shall be “reflective white,” “reflective blue,” and “reflective black.”

## **9.0 OPTIONS**

9.1 The unit shall be capable of communicating through a full duplex radio frequency (RF) communications system operating within the 2.4-2.485 frequency band (license free). It shall be capable of transmitting calls by means of radio frequency and then routing them into a PBX or central office line. Push-to-talk interfaces are not acceptable. Radio frequencies of 400 and 800-900 MHz are not acceptable due to frequency interference from other communications devices. Refer to the RF specification for further details.

9.2 The unit shall be capable of cellular communications instead of a hard-wire phone line. Refer to the cellular specification for further details.

9.3 An optional two-button version (Model CB3100-d) or a keypad version of the phone (Model CB3100-k) shall be available.

9.3.1 The two-button version (CB3100-d) features shall be as follows:

- There shall be a button labeled “Push for Help.” This button when touched will automatically activate the strobe and place a call.
- There shall be a button labeled “Info.” This button when activated shall automatically place a phone call to the pre-programmed number(s).

9.3.2 The keypad option (Model CB3100-k) features shall be as follows:

- There shall be a button labeled “Push for Help.” This button when touched will automatically activate the strobe and place a call.
- There shall be a button labeled “Call.” This button shall open the phone line for calls to be made from the keypad.

9.4 A solar powered ventilation fan (active) shall be available for applications where high humidity is prevalent.

9.5 With the use of the NightCharge™ option, it shall be possible to power the unit from a power grid that is not active 24 hours per day. Refer to the NightCharge™ specification for further details.

9.6 There shall be an option of customized paint colors and graphics. Colors other than standard shall be available based on RAL number specified by the user and approved by the manufacturer.

9.7 The unit shall be capable of accepting an integrated overhead camera mount that accepts a 1½ NPT dome camera supplied by others. The overhead camera mount shall be designed to be available and ordered with the CB I unit or as a retrofit to installed CB I units.

## **10.0 WARRANTY**

The unit shall be warranted for a period of two years. Reference manufacturers warranty for further details.

## **11.0 MANUFACTURER**

11.1 The Manufacturer shall be Code Blue Corporation of Holland, Michigan. There are no known equivalents.

11.2 Code Blue Corporation manufactures its products according to the most recent revision of product specifications, and shall not be held responsible for obsolete or outdated specifications. For the latest revision, please refer to [www.codeblue.com](http://www.codeblue.com).



## Installation

### Mechanical Installation

The first step in the Code Blue I installation is the pouring of the foundation. This foundation should be at least 24 inches in diameter, to the correct depth for the frost line in your area. (A depth of 36" is the recommended minimum depth.) Four 24" J bolts are supplied to anchor the Code Blue unit. These bolts should be set into the foundation such that 4 threaded inches are left showing above the surface of the foundation. Additionally, these J bolts should be aligned using the supplied template so that the phone faceplate on the unit faces the desired walkway. Lastly, electrical and telco conduit should be stubbed up through the center of the foundation.

Once the foundation has set, install one set of nuts and washers on the J bolts. Set the height of the nuts such that the bottom lip of the Code Blue unit is .5 inches above the level of the concrete. (Top of the washer should be roughly 2.5 inches above the concrete level.) Then set the Code Blue unit onto the J bolts, aligning the phone plate in the desired direction. Using the access door, install and tighten the second set of washers and nuts onto the J bolts.

*NOTE: The bollard should be mounted such that the bottom lip is 1/2 inch above the foundation level. Leaving the bollard snug to the foundation may create problems by not allowing adequate ventilation*

### Final Assembly

First, the high pressure sodium (HPS) fixture that was shipped with your Code Blue unit must be installed. The HPS lamp is shipped in the socket of the HPS fixture. Set the HPS fixture into the top of the unit, aligning the threaded fitting on the fixture with the corresponding hole in the unit. The power cord from the HPS fixture should then be plugged into the #1 cord. After this operation is complete, the white reflector plate should be placed in position over the HPS fixture. The reflector plate has notches to allow for the passage of the strobe top power cord extension.

The next component to be assembled is the strobe top. Insert the #3 plug from the strobe top assembly into the #3 cord receptacle on the top of the Code Blue unit. Drop the free end of the auxiliary cord coming from the bottom of the strobe top down into the bollard. Make sure the strobe top gasket is securely in place, to provide the proper weather seal. Align the holes in the cast base of the strobe top assembly with the drilled and tapped holes in the top of the bollard. Insert a 1/4-20 security screw into each of the three available holes, and tighten with the supplied security wrench.

Lastly, remove the emergency telephone from the bollard. Connect the gray auxiliary port connector from the phone to the mating connector from the strobe top assembly, and reinstall the telephone.

DATE	DESCRIPTION	BY	ITEM	QTY.	MAT'L	DESCRIPTION	DET. #
10/15/97	CHG BASE TO PUSH BUTTON	JEP					

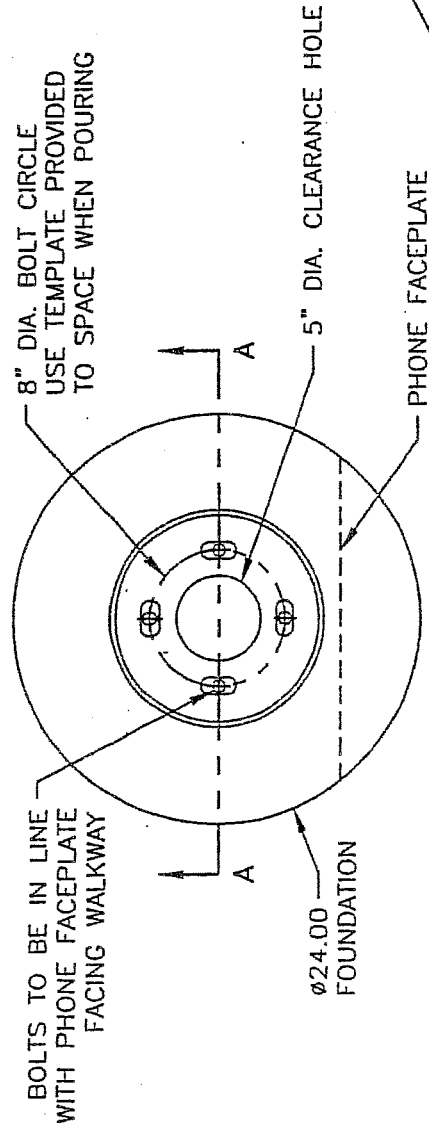

NOTE:  
USE LEVELING NUTS TO POSITION VERTICALLY SUGGESTED 1/4 TO 1/2 ABOVE CONCRETE. BASE TO PUSH BUTTON 45"

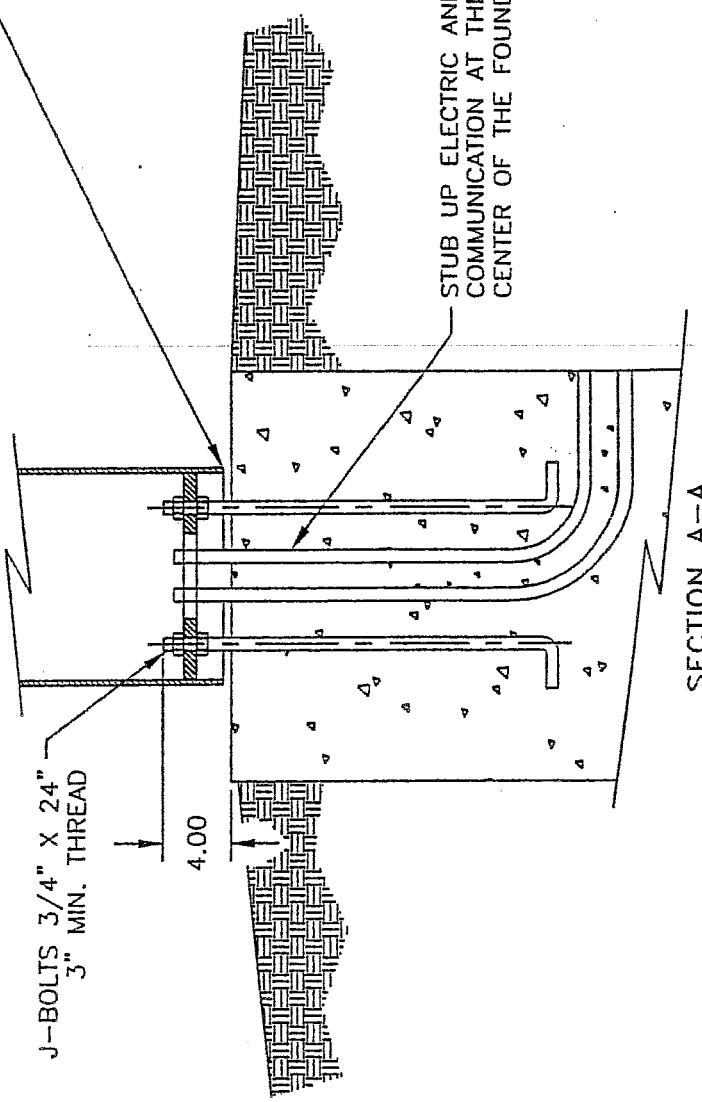

NOTE: CONCRETE DEPTH DEPENDENT UPON THE FROST LINE

DESCRIPTION		CODE BLUE CORPORATION	
TOLERANCES		INSTALLATION INSTRUCTIONS CBI	
X	= .100	DRAWN AT	SCALE 1=8
.XX	= .060	BY	DATE
.XXX	= .020	MJR	16 AUG 95
.XXXX	= .005	CHK BY	DATE
			11000
			A

THE DRAWING AND ALL PROPRIETARY RIGHTS AND CONCEPTS HEREIN ARE THE EXCLUSIVE PROPERTY OF CODE BLUE CORPORATION AND ARE NOT TO BE USED, DUPLICATED OR TREATED IN ANY WAY INCONSISTENT WITH SUCH RIGHTS WITHOUT PERMISSION OF CODE BLUE CORPORATION